

# **Air Warfare Applications of Laser Remote Sensing (Draft of RAAF APSC Working Paper #33, June, 1995)**

*Carlo Kopp†  
Carlo.Kopp@aus.net*

## *ABSTRACT*

Infrared Laser Remote Sensing has a number of very useful applications in air warfare. These are primarily in reconnaissance and Bomb Damage Assessment (BDA), and use derivatives of the established commercial Laser Remote Sensing technology base. Technical principles, implementation and operational constraints are discussed, as well as the limitations of the method.

## **Part 1.**

### **Laser Remote Sensing in Air Warfare**

#### **1. Introduction**

Laser Remote Sensing techniques are an established and mature scientific method used extensively in areas such as environmental monitoring and atmospheric research. Part 1 of this paper discusses specific problems inherent with established technologies applied to Reconnaissance, Surveillance and Bomb Damage Assessment, and proposes specific applications for Laser Remote Sensing methods, which resolve the ambiguities which may result from the use of established Reconnaissance, Surveillance and Bomb Damage Assessment sensors.

#### **2. The Limitations of Contemporary Optical BDA and Reconnaissance Methods**

Bomb Damage Assessment (BDA) has historically been a task of considerable difficulty, in that the wide range of munitions utilised, target types attacked and modes of attack used have precluded the application of any single reliable method.

The only wholly reliable method of Bomb Damage Assessment to date has been to overrun the target with friendly ground forces, and examine the damage inflicted by the air attack. This is understandably not a practical proposition in most situations, as the target may not be readily accessible, or it may be heavily defended on the ground. An alternative is to have locally deployed special operations forces observe the target from shorter distances, this method is however expensive as it uses a scarce wartime resource.

Air forces have traditionally relied upon photographic evidence to assess the damage inflicted upon the target. The photography may be carried out by the delivery aircraft with an onboard Bomb Damage Assessment camera, or by a post strike reconnaissance sortie flown by another aircraft. The latter has the advantage of potentially cleaner photography due to the absence of smoke and dust clouds produced by the

---

† Carlo Kopp is a practising computer industry consultant who has specialised in computer systems, communications and operating systems software. He has prior industry R&D experience both as an optical systems design engineer and systems integrator. As a Defence Technology Analyst writing for *Australian Aviation* journal in Canberra, he has produced technical features on modern military aviation since 1980. His other interests include the strategy, tactics and history of air warfare and electronic warfare, and private flying, particularly aerobatics and formation flying. He has contributed to the Royal Australian Air Force Air Power Studies Centre's working papers series since 1992.

delivered munitions' explosion, and better quality imagery due the use of specialised reconnaissance camera equipment.

Photography as a method for assessing bomb damage has its limitations. Static single frame images, using single aperture or stereoscopic photography, will suffer limitations in resolution due the film medium and camera's performance, as well as being unable to provide clear definition through haze, cloud, smoke or other obscurants. A clever opponent may successfully defeat conventional photographic reconnaissance by using camouflage or decoys with suitable accuracy in shape, size and contrast.

Thermal imaging or infra-red photography, using either FLIR (Forward Looking Infra-Red) equipment, or purpose designed reconnaissance linescan cameras, has provided some notable gains over conventional photographic methods of Bomb Damage Assessment. A thermal imager will register temperature differences in a target with contrast, or subject to postprocessing, false colour. Infrared radiation will also penetrate many obscurant aerosols far better than visible wavelengths, as the wavelengths are larger in relation to the aerosol particles in the atmosphere.

The ability to visualise temperature differences in a target image is a very useful tool in a Bomb Damage Assessment situation, as fires or recently burned equipment and buildings will register very clearly, as will running engines and any heat producing machinery. Camouflage and deception are complicated significantly when thermal imaging is being used, as the deceiver must replicate the thermal signature of the target, as well as its geometry and visible optical characteristics.

The advent of thermal imaging (FLIR) targeting systems such as Pave Tack, has added a new aspect to conventional Bomb Damage Assessment. These systems use a thermal imaging camera boresighted with a near infrared pulsed laser. The laser is used both for rangefinding and designation of targets with a coded pulse stream, for use by laser guided munitions. If the thermal imagery is fed into a video tape recording device, a real time record of the attack will exist for post flight analysis.

A video record of an air attack can be very revealing, in that it will show the target before the attack, during the explosion of the delivered munition, as well as during the immediate few seconds after explosion. This latter period is of interest as secondary explosions or fires may be evident, and a recording will provide the skilled observer with a good indication of the severity of damage inflicted upon many types of targets. The combination of a real time recording and the use of thermal imagery can thus provide considerably more accurate Bomb Damage Assessment than the use of older photographic methodology. A particular benefit of automated recording of thermal imagery is that it reduces the workload of a crew which at that point in the sortie will be very much focussed on egressing the target area.

The limitation of both photographic and thermal imaging methods is that they can only provide contrast information in the visible and infrared bands. While this is suitable for Bomb Damage Assessment and identification of many target types, it may not be adequate for assessing hardened targets or targets housed in hardened facilities. A very good example are bunkers used as command posts, and hardened aircraft shelters concealing aircraft. The Desert Storm air campaign is a good instance of this problem, in that many such targets were needlessly reattacked due to inadequate BDA.

A thermal imagery tape of an attack on such a target may reveal that the delivered weapon has successfully penetrated into the hardened shelter and detonated inside. The overpressure of thousands of psi inside the shelter will have forced open doors, hatches and vents, and this will have been visible in the taped imagery. It is therefore reasonable to assume that equipment and personnel inside the hardened shelter will have perished, however it is not possible to determine from such evidence whether the shelter contained either equipment or personnel. Only in the event that fuel or munitions of sufficient quantity were contained within the shelter to produce a large secondary explosion or fire, can it be said that a target of a given type has been destroyed within the shelter.

It is therefore not possible, using this technology, to analyse the contents of the shelter any more accurately. Should this be required, other means would be necessary.

Identification of potential targets using photographic and thermal imaging methods suffers the same generic limitations seen in BDA situations. A major issue in pre-strike or strategic reconnaissance is defeating camouflage and deception by a clever opponent. Again the basic limitations of the current technology base create opportunities for targets to elude detection. This is particularly true where the opponent has natural cover or uses radar and infrared opaque camouflage netting to conceal equipment or facilities.

### 3. An Introduction to Optical and Infrared Spectroscopy

Spectroscopy, or the method of optical spectrum analysis, has been used by physicists and chemists for over a century, to determine the composition of material samples, or the characteristics of light sources. Indeed, much of the activity in modern optical astronomy is centred upon the use of spectroscopic techniques to analyse the composition of radiating and absorbing bodies in outer space.

The underlying physical phenomena which allow a skilled observer to identify an emission type are firmly centred in the domain of quantum physics, and are well understood [EIS74], [RAMO65]. Much literature exists which details the theoretical and practical aspects of spectroscopic measurement techniques [SKOOG80], [WILLIAMS80].

Any material, if heated sufficiently, will emit light radiation of very specific wavelengths (colours), which are determined by the configuration of electrons orbiting the nuclei of the atoms in the material. Because the electron cloud surrounding a nucleus is unique for any given type of atom, and thus chemical element, the spectrum emitted by such a substance if suitably excited is a unique and unambiguous signature of the element in question.

Molecules of chemical compounds may also emit characteristic spectra if suitably excited, however these are very often at longer wavelengths such as in the near and mid infrared, and thus their detection and analysis requires equipment sensitive to infrared wavelengths.

Any light produced by combustion or intense heating will thus provide a good indication of the chemical composition of the combusted or heated material.

This physical effect is the basis of optical emission spectrographic measurement techniques. The term "emission spectroscopy" is based upon the usage of radiation emitted by the medium which is being measured. As such, emission spectrographic methods are passive in nature, in that they rely upon the measured medium to produce the light or infrared radiation used for measurement.

The limitation of emission spectrographic methods is that they require the medium which is measured to be heated to a high temperature, so as to excite the material to emit radiation. Providing that consistent heating and thus excitation is available, the method can be very effective, as evidenced by some of the work carried out by astronomers in recent times. Where the consistency of the thermal and transmission environment is questionable, the ability to derive accurate measurement may be compromised.

An alternative method, known as Optical Absorption Spectroscopy, resolves many of the limitations of emission based methods. Absorption spectroscopy involves passing light of known spectral characteristics through a target medium and observing which wavelengths are absorbed by the medium. Particular molecules will resonate at specific wavelengths, in doing so they absorb light at that wavelength. Unlike emission spectroscopy, which requires the target medium to be heated to a suitable temperature, absorption spectroscopy takes advantage of a light source provided by the measurement apparatus, this may be a laser of a suitable colour. As the laser has known wavelength characteristics, the target medium need not necessarily be heated to temperatures required to support emission based methods. Systems which use lasers as light sources are termed Lidars (Light Detection And Ranging - analogous to Radar).

A good example of the application of this technology is contemporary work in environment monitoring. Atmospheric pollutants are monitored by bouncing a laser beam off clouds which are overhead the measurement apparatus, or terrain behind the area of interest, or simply by analysing the backscatter from the atmosphere. The backscattered light from the laser, detected by the apparatus, has travelled twice through the volume of atmosphere, once outbound and one inbound to the detection apparatus. The laser wavelengths absorbed by the passage through the air give an accurate indication of the presence of particular chemical species, as well as their concentration. The provision of a light source of known characteristics, ie the laser in the apparatus, has avoided the potential difficulties of emission based methods[1].

Environmental monitoring work using Lidar started in the late sixties, with experiments which demonstrated that atmospheric concentrations of a few ppm of nitric oxide, carbon monoxide and sulphur dioxide, all fossil fuel burning byproducts, were detectable at ranges of about one kilometre. This work was carried out with a carbon-dioxide 10 micron band gas laser using DIAL (differential techniques - see Appendix)[MEASURES84 - pp384].

This technology has matured significantly in the last two and a half decades. Demonstrated results today cover a wide range of chemical compounds, a large proportion of which are associated with industrial activity, a byproduct of the increase in public sensitivity about environmental pollution.

The only publicly reported airborne military application of this technology is the US Army biological warfare agent detection system, designated XM94, which is described as being capable of detecting four different biological agents at ranges of up to 20 km. While little technical detail has been reported [EVERS94], the use of an onboard laser and computer equipment is a clear indication of the technology base used. An interesting point in this report is the stated difficulty encountered in filtering out the desired information from the background. This is entirely consistent with an absorption spectroscopic system.

This technology has a number of potential applications in modern air warfare. These include BDA, reconnaissance and chemical warfare agent detection.

#### **4. The Application of Laser Remote Sensing Methods to BDA and Reconnaissance**

Laser Remote Sensing has potential uses in the areas of reconnaissance and BDA. These uses derive from the ability of spectroscopic methods to measure the concentration of specific chemical substances in the air surrounding targets or potential targets. In reconnaissance situations, this involves detection of targets of interest, in BDA situations the detection of specific residues of the contents of a target structure.

In a BDA situation, attack by penetrating bombs (eg GBU-24/27 BLU-109) will produce significant overpressure within the target structure, blowing out vents, doors and hatches, during the process of which materials inside the target volume will be vented in particle or aerosol form. For instance, a fuelled and loaded aircraft within a HAS (Hardened Aircraft Shelter) will upon attack and secondary explosion vent aviation fuel vapour and possibly munition propellants and warhead explosives.

---

[1] Typical contemporary applications will use a laser which is tunable, and usually tuned to the specific wavelength of interest. Should several substances be searched for, then the laser is typically retuned to the appropriate wavelength for the measurement. This is usually achieved by using optical resonators or diffraction gratings, which selectively reinforce lasing at the desired wavelength. Conventional lasers using Fabry-Perot cavities will usually produce a range of wavelengths concurrently, and the addition of the selective tuning element in the optical path will suppress lasing at undesired wavelengths. In this fashion a spectral range can be covered, and given the capability of the laser, many spectral lines associated with a range of chemical species can then be collected.

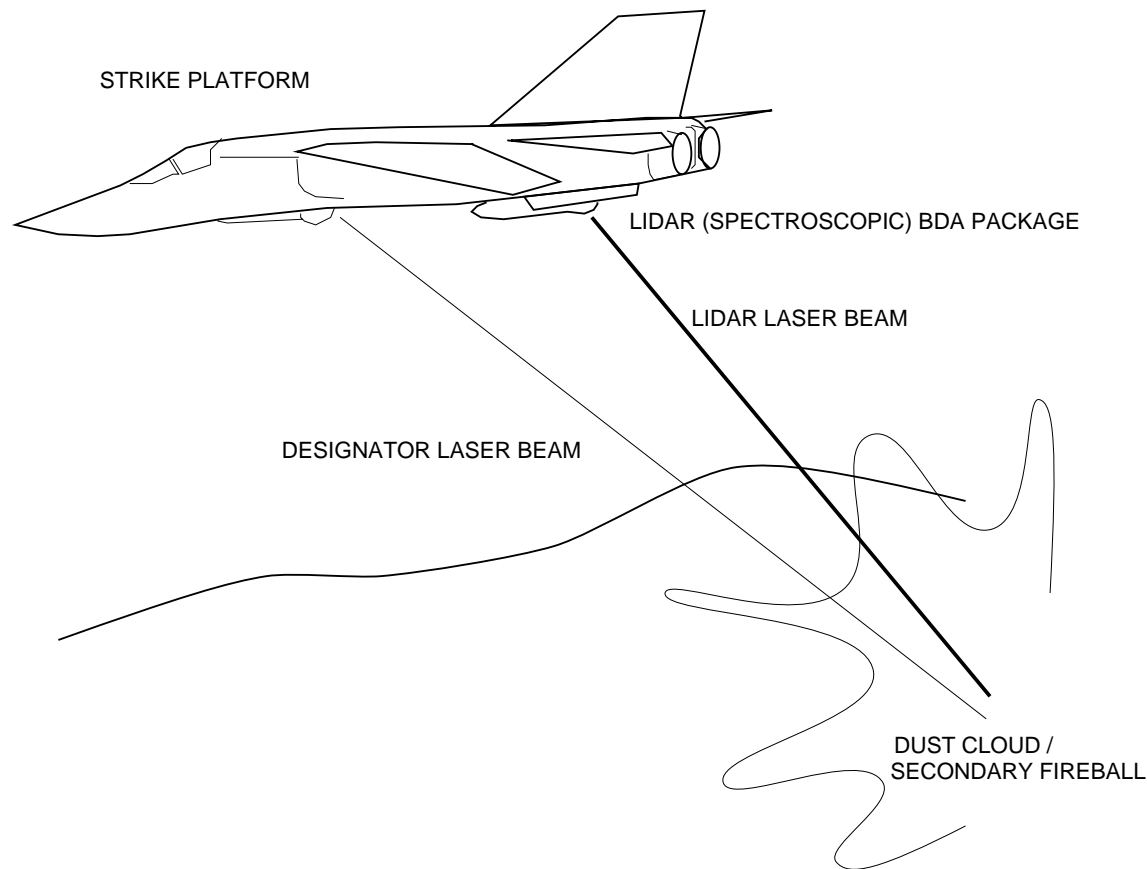

**FIG 1. LIDAR (OPTICAL ABSORPTION) SPECTROMETER USED AS BDA SENSOR**

Should the attacking aircraft be carrying a suitable Laser Remote Sensing Lidar device [Fig.1], it could measure the composition of the residue cloud or target fireball. This could provide information allowing targeters to draw conclusions about the contents of the shelter. The results of such measurement can then be used to supplement the BDA video and assist in determining what the shelter contained [2].

This can be of particular importance should the targeted shelter have possibly contained chemical warfare agents or aircraft or missiles equipped with chemical warfare agent warheads. Suppression of an opponents CW capability will in most air campaigns be a priority in the opening phases of the strategic air attack campaign, and confirmation of target destruction by detection of agent type and concentration could be particularly valuable when assigning priority to use of strategic air assets.

In a reconnaissance situation, conventional photographic and thermal imaging sensors have similar limitations to those experienced in BDA situations. The result of this is often ambiguity in the detection of subjects of interest. The ability to detect low concentrations of chemical substances in the atmosphere is therefore a potentially very useful reconnaissance tool, which could flag the presence of a possible target in an otherwise ambiguous image.

Most military activity is by its nature bound to a logistical tail and this logistical tail will advertise its presence by contaminating its surroundings with fuel vapour and internal combustion engine exhaust gasses. Furthermore, production and loading of many militarily useful materials, in particular explosives

[2] Measures describes a number of mobile Lidar systems used for measuring the composition of power station smokestack emissions. The exhaust from such smokestacks is not only hot, but will also contain a substantial amount of ash. In this respect, it is reasonable to expect similar optical properties to the smoke and dust clouds vented from a shelter hit by a munition [pp408].

and chemical warfare agents, will usually result in a greater or lesser degree of contamination in the surrounding environment, as evidenced by the Gulf Campaign.

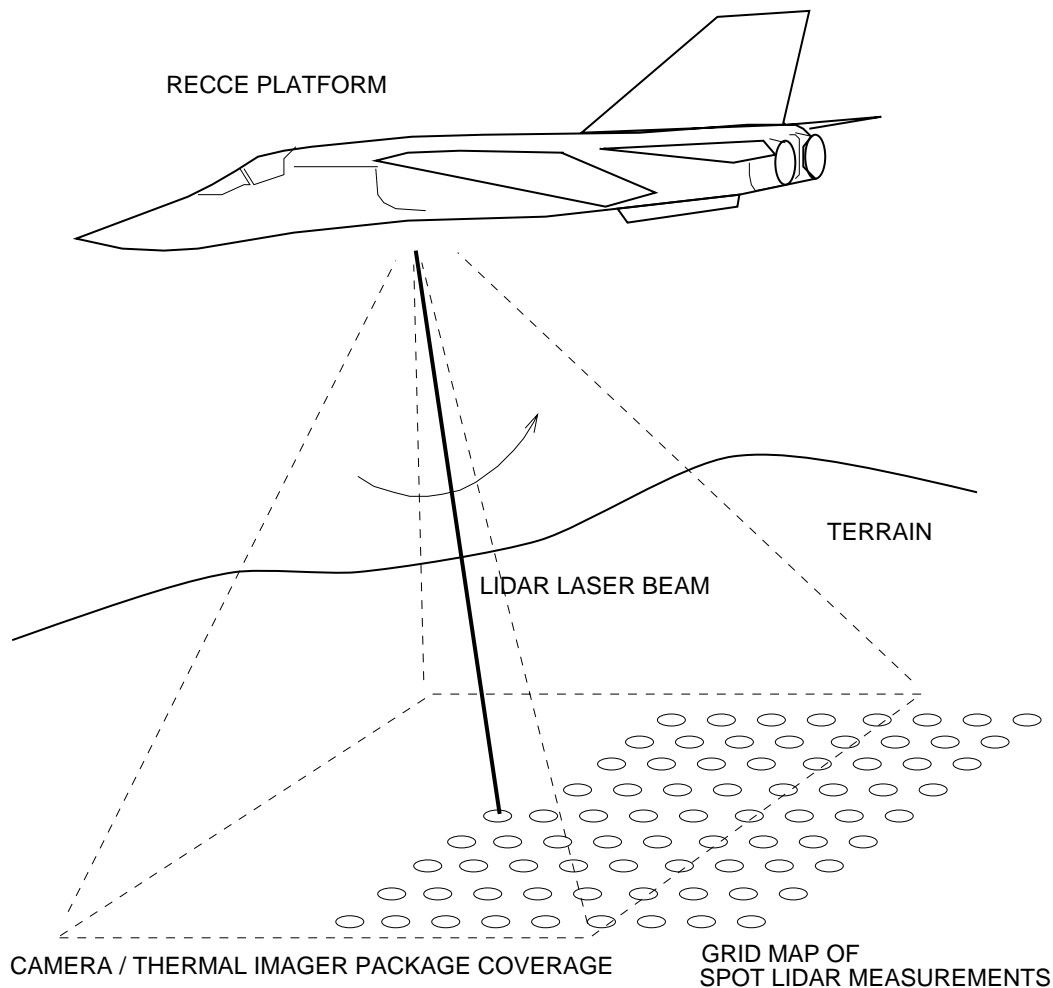

**FIG 2.1. LIDAR (OPTICAL ABSORPTION) SPECTROMETER USED AS RECCE SENSOR**

A suitable Laser Remote Sensing spectrometer [3] with the capability to measure the atmospheric concentration of such telltale substances, at a distance, could be used to provide a chemical trace "map" of an area of interest. A reconnaissance package on an aircraft so equipped [Fig.2.1] would sweep its Lidar over the terrain beneath the aircraft, taking a grid of point measurements. As the laser "spot" would be reflected off the surface of the earth, concentrations at ground level could be measured. Where an area of interest is not particularly well ventilated by wind, telltale chemical traces may be concentrated, further increasing the sensitivity of the method.

[3] Measures describes a number of experiments which are relevant to this discussion. What is of particular importance is that the CH<sub>3</sub> group associated with straight chain hydrocarbons, contained in jet fuels and some automotive fuels, has a resonance in the 3.5 micron infrared band. This means that an instrument designed to detect this spectral line can in fact identify the presence of a range of hydrocarbons concurrently. Examples of hydrocarbon detection include experiments where ethylene concentrations of 10 ppb were detected from backscatter off foliage at 5 km distance, using a 15J/100 nsec pulsed carbon dioxide laser with 300 mm diameter receiver optics. Another experiment detailed in this reference involved the remote detection of methane concentrations of 2 to 4 ppm, using a 3.3 micron wavelength laser (pp391, 394). Automotive and jet fuels contain a number of volatile components, and a substantial fraction of aromatics. Jet fuels such as Jet-B (D-1655) or JP-4 (MIL-J-5624F) are typically a blend of gasoline and kerosene, with an aromatic content of about 20-25%, and an alkene content of about 5% [TREAGER79].

Should the grid map have appropriate density, postprocessing software could be used to produce other forms of presentation, such as false colour contour maps of equal concentration levels of chemicals of interest. These may then be overlaid over photographic or thermal images of the area of interest, to ease the photointerpreter's task.

Hidden fuel storage depots would be a typical target of such reconnaissance. Because fuel tanks will typically vent hydrocarbon (fuel) vapour, so as to avoid the buildup of dangerous vapour pressures, any storage farm no matter how well hidden will produce a telltale vapour trace in the atmosphere above its location. Spillage is another good source of contamination. Similarly explosives or chemical warfare agent storage and loading facilities will also, unless particularly well filtered, identify their presence.

Existing methods such as thermal imaging or ground penetrating radar can both provide an indication of the presence of a buried facility. However, unless other means are used, it may be very difficult to establish beyond reasonable doubt what is the nature of the facility. The use of absorption spectroscopy could provide a means of narrowing down the options when assessing other reconnaissance sensor outputs.

The detection of automotive exhaust gasses is another potential application for such technology [4]. The deployment and hiding of military vehicles in wooded areas has been a traditional means of concentrating resources out of the sight of the opponent's air power. A good example is the NVA effort along the Ho-Chi-Minh trail, during the SEA conflict, or Wehrmacht operations in the Ardenne.

A concentration map of exhaust gas traces could be used as a means of establishing whether the opponent has concentrated land warfare assets in a given area. This could in turn be used to cue subsequent reconnaissance with other sensors to confirm whether the observation was accurate or not. Where the presence of such forces is already known, impending activity such as preparations to move out of established positions may be detected once engines are cranked up and run in large numbers. This kind of early warning of movements is not provided by radar, which requires the vehicles to be moving. It is worth noting that early warning of impending activity by monitoring radar and communications emissions will not necessarily be available with a low technology opponent, or a very electronically disciplined opponent.

A similar approach could be used to detect hidden heavy artillery emplacements. The propellants used by such weapons will leave a respectable trace of nitrogen oxides after firing. Providing that the Lidar scans over the emplacement within such a time interval, that the propellant residue cloud has not dispersed adequately, it is reasonable to expect such a trace to be detected [5]. Where the opponent is using self-propelled artillery, and moving position after firing, a combination of nitrogen oxide and exhaust gas monitoring scans will provide a trace to the current position of the SP artillery piece.

Another potential area of use could be searching for dispersed mobile ballistic missile launchers. Older technology missiles such as the Scud are liquid fuelled, and where such missiles need to be fuelled before launch, it is likely that propellant spillage from hoses could provide a detectable chemical trace. Should such traces be detected in conjunction with automotive fuel and exhaust gas residues, it would be reasonable to assume that a ballistic missile is being prepared for launch [5].

---

[4] *ibid* pp388. Internal combustion engine exhaust gasses contain a number of readily detectable trace substances. Nitric oxide, carbon monoxide and ethylene are notable instances, although a range of hydrocarbons may also be present. Experiments in monitoring carbon monoxide concentrations in an urban area detected the starting and stopping of an automobile engine, against a background concentration of about 400 ppb of carbon monoxide. The tests involved a carbon dioxide laser. Other experiments [pp389] detected nitric oxide concentrations of 300 to 400 ppb, against a background of about 100 ppb, with peaks associated with the presence of individual busses and trucks. Hydrocarbons may also be an attractive trace for such applications, ethylene in particular as its natural background concentrations are very low [pp8, pp9].

[5] *ibid*. pp 392. A frequency doubled carbon dioxide Lidar emitting in the 5.3 micron band was used to detect nitric oxide concentrations of about 250 ppb at a range in excess of 1 km. Nitrous oxide concentrations of about 290 ppb have been detected by a 3.9 micron band Lidar at ranges of several kilometres, while nitrogen dioxide has been successfully measured by a 450 nanometre band frequency doubled dye laser Lidar at concentrations of about 25 ppb at an unspecified range [pp398].

*ibid*. pp391. A relevant experiment detailed the detection of 100 ppb of toxic rocket fuel over distances between 0.5 and 5 km, using the 5.3 micron Lidar detailed above. Rocket fuels such as hydrazine, unsymmetrical dimethyl-hydrazine and monomethyl-hydrazine all have resonances within the coverage of the 10.6 micron band carbon dioxide laser [pp394].

The reconnaissance Lidar scheme proposed above employs a down looking Lidar, as current technology has performance constraints which limit useful range to several kilometres of distance. Should the range performance of such Lidars be significantly improved, for instance by one or one and a half orders of magnitude, then other more elaborate mapping schemes may be used. An example would be a side looking arrangement, using a horizontal scan [Fig.2.2], where the aircraft would fly along the FEBA and look into hostile airspace from the sanctuary of sanitised airspace. This scheme would have the further advantage of allowing the use of more sophisticated map imaging schemes [see Appendix], including tomographic post-processing algorithms, which are used in medical imaging [ibid.pp395]. This would allow the construction of a more accurate picture of the chemical traces in the area of interest. Colocating such equipment on a battlefield surveillance platform with a sidelooking radar (SLAR) would then allow the fusion of radar Moving Target Indicator (MTI) imagery, synthetic aperture (SAR) groundmapping radar imagery and Lidar chemical trace concentration imagery. This would significantly improve confidence in target tracking and identification.

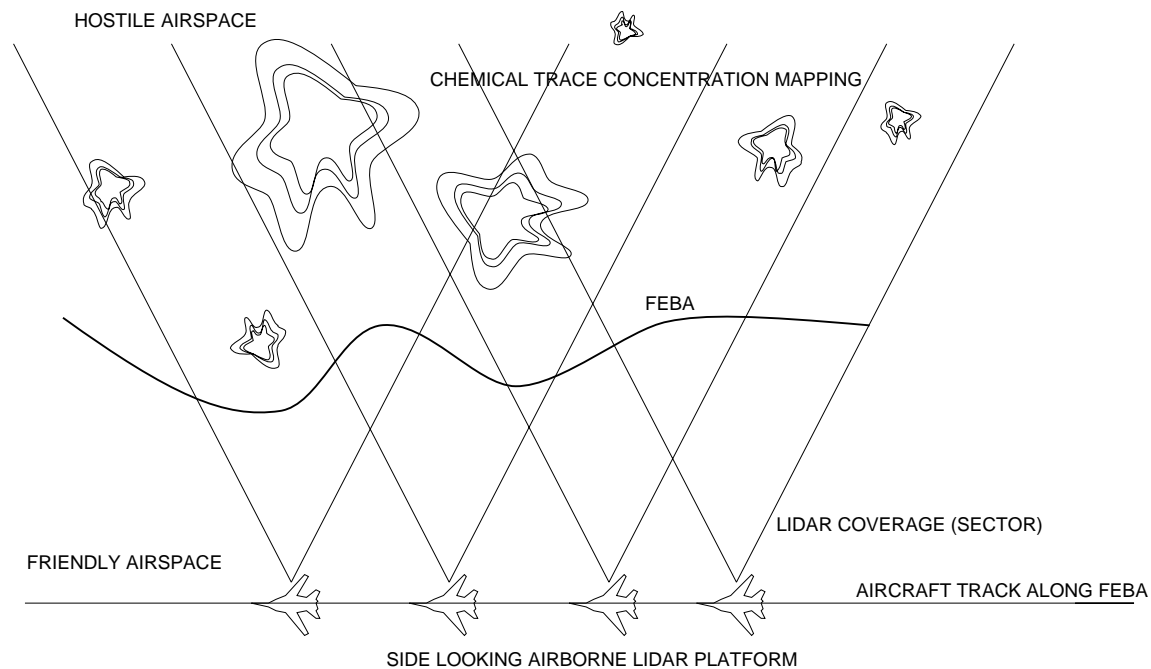

**FIG 2.2. SIDE LOOKING AIRBORNE LIDAR (SLAL) ARRANGEMENT - STANDOFF SURVEILLANCE**

An issue which may become important, in the context of the air land battle, is the proliferation of stealth technology. The US Army has expended much effort on the Comanche scout helicopter project, which has been designed with a very low frontal radar cross section, and significantly reduced infrared signature, in comparison with types currently in service. Battlefield helicopters in this class may be very difficult to detect using conventional battlefield surveillance radars (JSTARS, Orchidee, ASTOR) or AEW systems (E-3). Helicopters in NOE (Nap-Of-the-Earth) flight and hover are in a moderate to high engine power regime, and all the fuel burned ends up as a cloud of exhaust gas surrounding the position of the helo. This exhaust gas signature may not disperse well, particularly if the helicopter is masking itself in foliage, as one would expect it to. Should a battlefield surveillance Lidar be built with sufficient sensitivity and resolution to track armoured vehicles, it should also have the capability to defeat the stealthy battlefield helicopter (NB this approach may also be effective against fixed wing stealth aircraft, as a jet aircraft exhaust trail will contain concentrations of hydrocarbons of the order of parts per million, which can be 100 or more times the background atmospheric concentration [ibid pp8, pp9]).

Detection of chemical warfare agents has been proposed in the BDA and reconnaissance situations. Its usefulness in a standoff battlefield surveillance platform as a means of early warning of chemical attack in progress is clearly obvious.



A note of anecdotal interest here is the USAF effort to track the VC by using chemical sniffer equipped aircraft, which searched for the vapour residues of human urine. When the communists eventually learned of this, they took to hanging jars of urine off trees to deceive the sensors. The technology of the day was unable to defeat a simple deception technique. The use of a more sophisticated remote absorption spectroscopic sensor could defeat such a countermeasure, as it could concurrently search for more than one chemical trace of interest, such as the presence of exhaust gasses, thereby making simple deception far more difficult.

For deception to be successful, multiple channels of deception must be used. The ability to search for a wide range of chemical traces, as well as thermal and visible optical images, creates a much wider range of information channels than can be dealt with by a conventional deception strategy. Should an opponent become aware of a chemical trace detection capability, that opponent will be faced with the difficulty of knowing what deception to use, and this uncertainty will impose additional pressure in the decision making process.

### **5. The Limitations of Laser Remote Sensing in Reconnaissance and BDA Applications**

While Laser Remote Sensing techniques offer the potential to unambiguously identify chemical substances in an area of interest, the method has its limitations.

The first limitation is in the need to carry specialised equipment in addition to existing reconnaissance sensors or Bomb Damage Assessment cameras. This must inherently add weight to the aircraft's sensor suite, as well as increasing the cost and maintenance requirements of the aircraft's systems.

The second limitation lies in the attenuating properties of the atmosphere and obscurants such as dust, haze, water vapour or low cloud. These will attenuate the laser radiation reflected by the target, both by scattering and selective absorption. This will limit the range at which any given airborne spectroscopic sensor can accurately take a reading off a target, as well as impose weather constraints upon the usage of the method.

The greater the range and atmospheric losses, the larger the optics, the more powerful the laser and the more sensitive the detector required in the equipment. Ultimately this will place limits upon the useful range of such equipment of any given size and technology.

The final noteworthy limitation of Laser Remote Sensing methods is their potential vulnerability, as with conventional photographic methods, to deception by a clever opponent. A HAS filled with 44 Gal drums of aviation fuel, expired missile rocket motors and spare tyres would be likely to register similar chemical signatures to a real aeroplane, should the HAS be successfully attacked and analysed by a Lidar. A similar tactic could be applied to creating bogus underground fuel tanks or vehicle concentrations. Whether the effort justifies the result is however open to debate.

Deception is however less likely to succeed should multiple reconnaissance or BDA sensors be used, and a combination of thermal imaging and Laser Remote Sensing techniques would provide substantially better resilience to deception than either method alone.

### **6. Integration of Laser Remote Sensing Methods into the Strike Operations Cycle**

The integration of Laser Remote Sensing techniques into the strike operations cycle is a simple task. The conventional strike operations cycle is comprised of pre-strike reconnaissance, identification of targets and/or aimpoints, selection of munitions and mode of attack, flying the sortie(s), taking BDA imagery during the attack, and typically flying a post strike photoreconnaissance sortie to assess the final condition of the target.

The availability of airborne Lidar equipment suitable for reconnaissance and BDA purposes would not introduce any notable changes in the strike operations cycle. Preflight preparations of the aircraft would require loading of magnetic tape cartridges for the Lidar equipment, this in addition to all of the other

---

[6] Other effects which can influence accuracy in BDA situations are Doppler shifts in spectral components resulting from violent turbulence during explosions and combustion, as well as broadening of spectral lines due thermal motion of atoms or molecules in such environments. Both of these effects need to be accounted for in postprocessing.

preflight weapon and system loading tasks.

Making the reasonable assumption that a BDA or reconnaissance role customised Lidar would be integrated with the aircraft's mission avionic suite, no changes would be required to the conventional mission profile. Some additional prestrike checks may be required, to verify that the device is armed and ready, prior to the overflight of the target.

In the instance of a reconnaissance sortie, the Lidar would be activated concurrently with the camera equipment whilst overflying an area of interest, and would produce a map of concentrations which would cover the area photographed by the camera equipment.

The post mission analysis of reconnaissance camera, strike camera or targeting system images would be supplemented by the analysis of spectroscopic data recorded during the mission. As this could be largely accomplished in software on a desktop computer, the task would largely devolve down to transferring data from the aircraft to the computer, and interpreting the results. Ideally most of the interpretation would be performed by the software, which could list the probable equipment or material types detected in the area of coverage.

The reconnaissance or BDA report would therefore contain in addition to information now included, a spectrograph report or map detailing the collected readings. This information would be used to complement the photographic or thermal imaging data.

## Part 2.

### Implementation Issues in Airborne Laser Remote Sensing Lidars

#### 7. Introduction

The implementation of airborne Lidar based sensors for the purposes of Reconnaissance, Surveillance and Bomb Damage Assessment is a technically non-trivial task. The implementor of such a sensor will have to resolve a number of important tradeoffs in performance, sensor capability and packaging. Part 2 of this paper reviews the technological issues confronting the designer, and outlines a number of possible approaches to solving this problem.

#### 8. Performance Constraints in Airborne Lidars

The design and implementation of an airborne optical spectrographic sensor is primarily an engineering problem. Existing remote environmental monitoring instruments can perform a range of analogous functions [MEASURES84] and the adaptation of this technology base to the applications described in this paper is primarily an exercise in customised design and packaging. Indeed, the CSIRO's airborne laser remote sensing system [WHITBOURN90] is a good example of a closely related system [7] used for practical research. To accommodate the applications discussed here, some further effort may be required in cataloguing the spectral signatures of substances of interest. This is a scientifically well understood process.

As with most technological solutions, a range of possible implementations exist, and production of any such device would reflect design specification parameters such as sensitivity, wavelength resolution, angular coverage, response time and recording medium. All of these parameters have an important bearing on the performance and cost of the device.

Range performance is critically dependent upon receiver sensitivity and laser output power. The better the sensitivity of the device, and the larger the delivered laser optical power, the greater the useful distance at which a measurement may be taken. On an airborne platform, tracking performance and angular jitter will also serve to limit the useful range of the sensor.

---

[7] This system was designed to produce 10 micron band measurements of mineral reflectivity. The system is carried by a Fokker F27, on an internal pallet, and produces a 2 metre diameter laser spot from an altitude of about 1,500 ft. Of particular interest in this design is the carbon dioxide laser, which is tuned through about 100 separate wavelengths in the 9 to 11 micron range available from the carbon dioxide lasing medium. The laser produces a peak pulse power in the range of 50 to 100 Watts, and uses a folded cavity with a 3 metre optical length. While this system is customised for its application, it could be readily adapted to trialling the applications discussed in this paper by additional signal processing hardware to provide for a DIAL mode of operation.

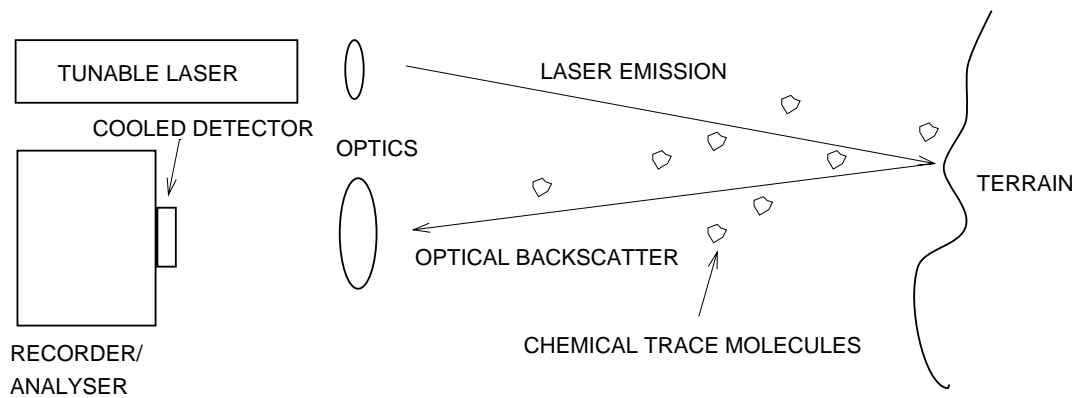

FIG.3.1 SIMPLIFIED SCHEMATIC OF AN LIDAR (ABSORPTION) SPECTROMETER

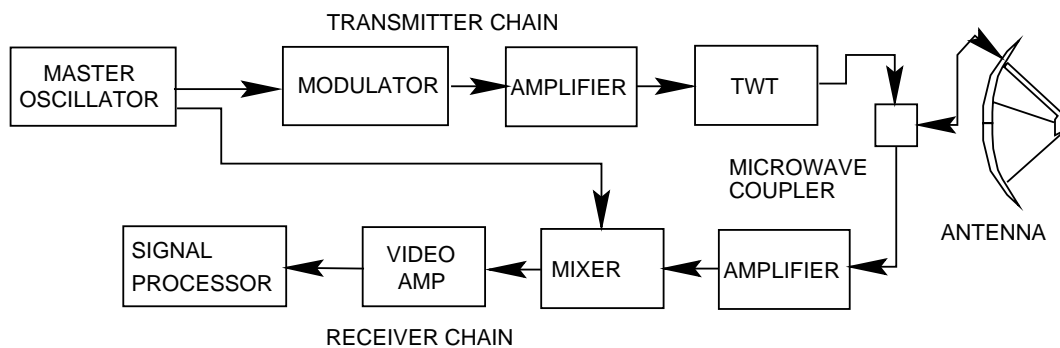

FIG.3.2 GROUNDMAPIING RADAR - FUNCTIONAL MODEL

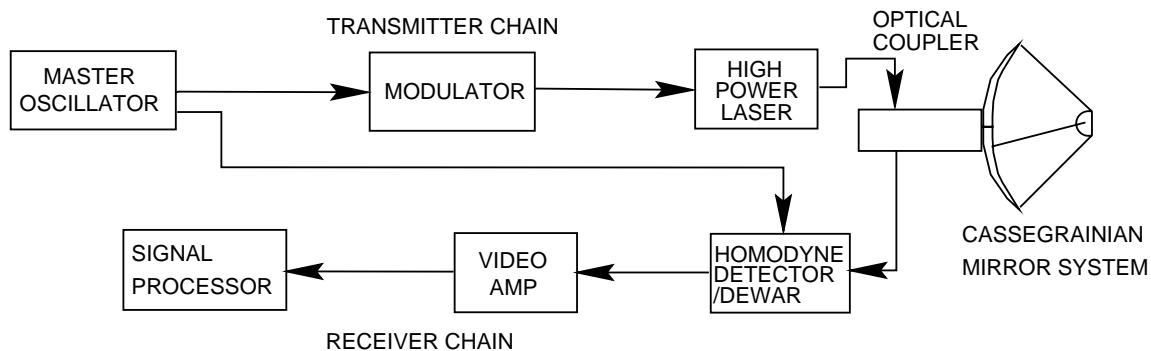

FIG.3.3 SPECTROMETER LIDAR - FUNCTIONAL MODEL

Wavelength resolution is a measure of how fine a picture of the spectrum can be produced by the sensor. The finer the resolution, the more potentially capable the sensor. The choice of a resolution will therefore be determined by the application, and excessive capability in this area may not be warranted.

Response time is a measure of how long a single measurement takes. For an airborne tactical application, a response time of milliseconds is desirable, to avoid the effects of the aircraft's linear and angular motion. This constraint will have a bearing on both receiver design and laser pulse performance in Lidar equipment.

The recording medium used will affect both the post mission processing time of the data, as well as the amount of data to be saved in a single measurement. Digital storage in magnetic media would be the most practical proposition at this time.

Sensitivity performance will be determined by the type of detection device, the quality of the optics, the sample (measurement) period, the performance of the receiver channel and its digital to analogue converter and the type of processing or postprocessing carried out on the collected data. Detector performance

is critical, in terms of electrical noise performance, electrical response to illumination, spectral responsivity and dynamic range performance [8].

## 9. Implementation Options in Airborne Lidar Sensors

Lidars and DIAL Lidars usually employ a single detector element, which is made from a suitable material such as Indium Antimonide (InSb - common to the AIM-9L/M Sidewinder seeker) for 3-4 micron band operation, or Mercury Cadmium Telluride (HgCdTe) which is commonly used in 10 micron band thermal imaging equipment. Thermal noise performance requirements dictate detector cooling, as with missile seekers and thermal imagers.

The design of the receiver channel which amplifies the output from the detector element is another area which can significantly impact system performance. The best achieved performance with contemporary technology has been produced by the use of coherent detection techniques. These techniques are analogous to the super-heterodyne model which has dominated radio receiver design for the last five decades, and provide for significant receiver channel amplifications [9].

Laser Remote Sensing Lidars [Fig.3] as proposed in this paper for use in BDA and reconnaissance applications, are complicated technically by the need to carry a suitable laser which is boresighted with the spectrometer's receiver optics. This laser needs to be rapidly tunable in order to cover the range of wavelengths required to detect substances of interest, as well as being capable of delivering the required power level to provide for a detectable return scattered off arbitrary terrain. It is worth noting here that the detected backscatter return can be very faint, often 9 orders of magnitude lower than the emitted power of

---

[8] The lower limit on the detection performance of any such system is determined by the detector's noise performance, usually quantified as Noise Equivalent Power (NEP). Electrical noise in a semiconductor detector device will tend to mask the faint electrical response from a weak target, and the limit to the performance of any detector is given by the point at which the electrical energy from the target backscatter becomes comparable in magnitude to the noise energy produced by the detector.

The principal noise mechanisms are thermal noise and shot noise, the latter produced by detector dark (leakage) current and background illumination. Thermal and dark current shot noise may be reduced by cooling the detector. Background illumination can not be suppressed by optical filters if it covers the same wavelengths as the measurement. Night operations and clever postprocessing may somewhat reduce its effects. The next critical noise source is the detector first stage amplifier which boosts the electrical signal produced by the detector. Good design technique can reduce its effect significantly.

Spectral responsivity is a measure of what wavelengths (colours) the detector may respond to. Typical materials such as Silicon have severe performance limitations in the near infrared part of the spectrum, but perform satisfactorily at visible wavelengths. Infrared operation dictates the use of materials such as InSb and HgCdTe.

Dynamic range performance is a measure of the difference between the brightest and dimmest targets which the device can handle. It is an important parameter in an airborne application as it allows the use of the sensor over a wider range of distances and atmospheric conditions.

A more detailed discussion of the importance of these parameters is contained in [MEASURES84].

[9] Coherent detection systems will mix a reference optical signal (in a heterodyne system a reference laser source at a slightly different wavelength from the primary laser transmitter), with the detected backscatter signal. The addition of the two optical signals in the detector element, which is electrically non-linear, will produce the same effect as the use of a mixer in a superhet radio, resulting in an alternating current output from the detector. This current has a frequency determined by the difference in the frequencies of the reference laser and the backscattered laser radiation. Its magnitude is proportional to the magnitude of the detected backscatter from the target. Such a signal is readily amplified by a conventional radio (RF) receiver chain, which can be built with a very high gain (amplification).

A simpler design alternative to the heterodyne receiver is the homodyne receiver, which taps energy from the primary laser source. Its detector will produce a baseband (with a DC component) output, similar to radar video, which must then be amplified by a wideband receiver chain. As high performance wideband amplifiers are more difficult to build than RF receivers, the simplicity of the optical subsystem must be balanced against the problems of receiver channel design.

In either instance, the design of suitable receiver chains is a mature art, with decades of cumulative experience in radar and communications applications.

the laser device. This is why receiver channel performance is so critical to success in this technology area.

The best accuracy in Lidar applications has been achieved by the use of DIAL (Differential Absorption Lidar) techniques. In a DIAL Lidar, each measurement involves the transmission of two separate laser pulses. One pulse is at the wavelength of interest, the other is at a wavelength tuned slightly off the first and thus not absorbed by the measured species. Transmitting the second pulse allows compensation for all transmission path losses, such as unknown terrain reflectivity and the condition of the atmosphere. Subtraction of the two backscatter measurements yields a difference which is the absorption due to the chemical species of interest. This is a very simple, robust and elegant technique in which much of the calibration effort of other spectroscopic methods is avoided.

As the principal chemical species of interest have resonances which lie in the 2 to 10 micron band, infrared lasers such as the 10.6 micron carbon dioxide laser would need to be used. These lasers can be precisely tuned with optical diffraction gratings, and pulsed via Q-switch or other techniques. Harmonics at multiples of the fundamental laser frequency can be produced using non-linear optical materials. Termed Parametric Oscillators, such optical systems will produce frequencies which are typically double or triple the frequency of the laser used to pump the optically non-linear crystal. In this fashion a single laser can be used to produce a range of wavelengths. It is worth noting that the design of a tunable higher power laser source is a non-trivial task.

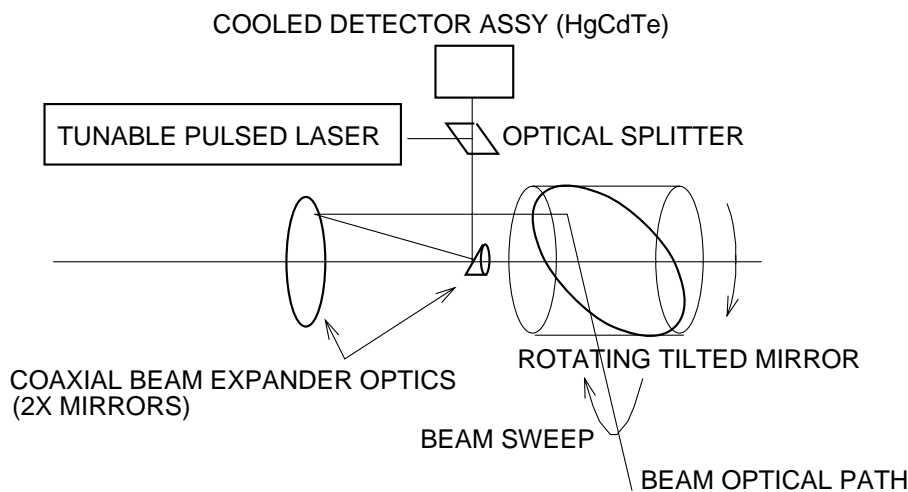

**FIG.4 SIMPLIFIED SCHEMATIC OF A LIDAR SPECTROMETER HEAD (RECCE SENSOR)**

A typical infrared Lidar used for atmospheric remote sensing employs a single infrared detector element using a material such as InSb or HgCdTe. Cooling of the detector is no different than that used for existing applications such as infrared trackers. Frequency calibration to wavelengths of interest is performed by tuning the laser. If several species are being searched for, these must all have resonances within the tuning range of the laser, and the Lidar control system will have to retune the laser twice for every measurement. The output from the detector element is then detected, digitised and stored.

Carriage of an Laser Remote Sensing device on a combat aircraft raises a number of interesting issues.

Ideally a BDA Laser Remote Sensing Lidar would be a device integrated into the sensor head or turret of a targeting sensor such as the AVQ-26 Pave Tack or the AAS-38. In this arrangement the spectrometer would be boresighted with the existing optics, and thus would produce readings of whatever scene is recorded by the electronics in the imaging system [10].

[10] The packaging density of such equipment currently precludes the addition of a spectroscopic sensor into an existing design at modest cost. The principal constraint is the large size of current carbon dioxide mid-infrared lasers. Should a suitable compact solid state mid infrared laser become available, this situation could change. It is worth noting that Lidar performance is enhanced by using larger light gathering optics, as is the case with thermal imagers. Where a targeting sensor uses an existing mid infrared band sensor, such as a thermal imager, integration may be easier in that an optical splitter may allow both the thermal imaging sensor and the Lidar

This arrangement is also convenient in that the inherent boresight calibration removes any uncertainties as to the source of the measured species. The field of view (FOV) of the sensor is nevertheless an issue, and the optics used must have such a focal length to provide an appropriate instantaneous field of view for the range to target required. In thermal imaging or optical cameras this problem is typically addressed by using selectable narrow and wide FOV modes in the optics.

A costlier arrangement is the use of a standalone spectrometer device. If such a device is to be used for conventional BDA, it would require an aft facing and preferably steerable optical head, which would be cued at the target by the aircraft's offensive avionic system. A podded installation could be carried on a fuselage or wing station, although it is arguable that an ancillary sensor of this variety should not tie up weapon stations.

A Lidar for reconnaissance purposes is a more complex proposition, as the optical head must be designed to provide for rapid and periodical sweeps to either side abeam of the aircraft [Fig.4], much like an infrared line scanner. One would expect that the sensor would take a series of spot measurements during each sweep, and be capable of storing the results of each spot "snapshot" on to a magnetic storage medium such as a tape drive. Each measurement would have to include encoded geographical coordinates derived from the carrying aircraft's nav attack system. Assuming the use of DIAL techniques, it would be reasonable to carry out the differencing of the returns prior to storing the data, thereby simplifying the postprocessing on the ground. The latter would then reduce to the calculation of a concentration map for each species detected. A constraint in a non-range gated scanned application will be adjacent measurement cell overlap with increasing beam deflection off the flightpath centreline, this will constrain the coverage of the sensor.

Whether to install the sensor in a pod, or a fuselage pallet would be an implementation issue. the necessity to carry a laser as well as the remaining electro-optical hardware will incur a weight and a power drain penalty. The additional cost and complexity of such a sensor would be offset by the fact that only a few units would be needed, and these fitted to dedicated reconnaissance aircraft (eg RF-111C).

The pod arrangement depicted in [Fig.5] is based upon the existing Laser Remote Sensing Lidar technology base, and involves primarily repackaging to fit into a pod suitable for carriage by a tactical jet.

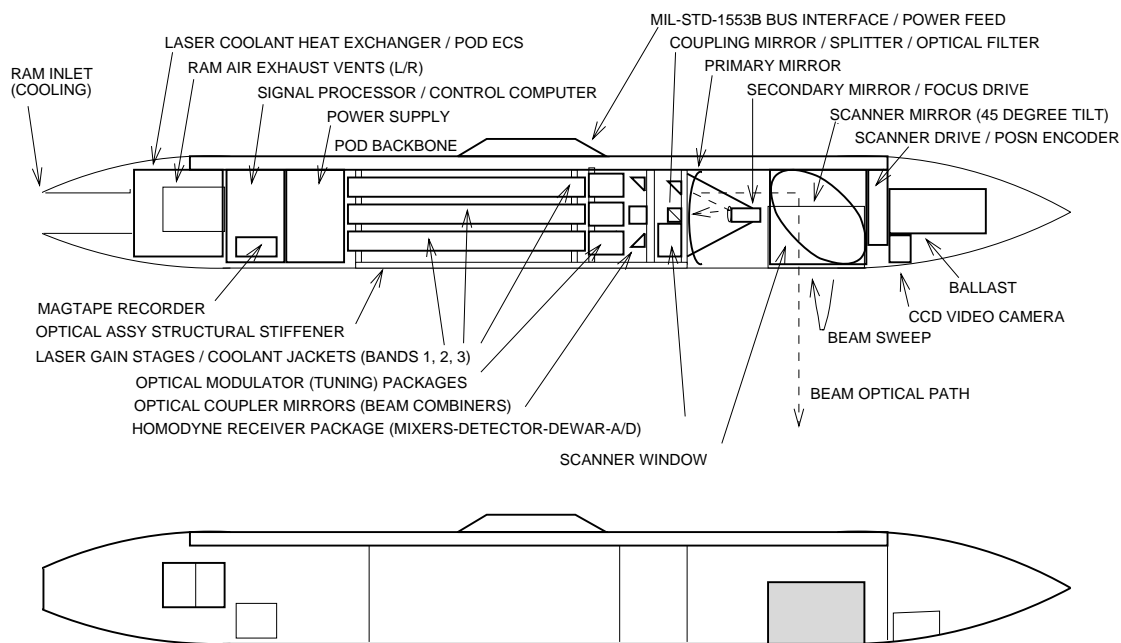
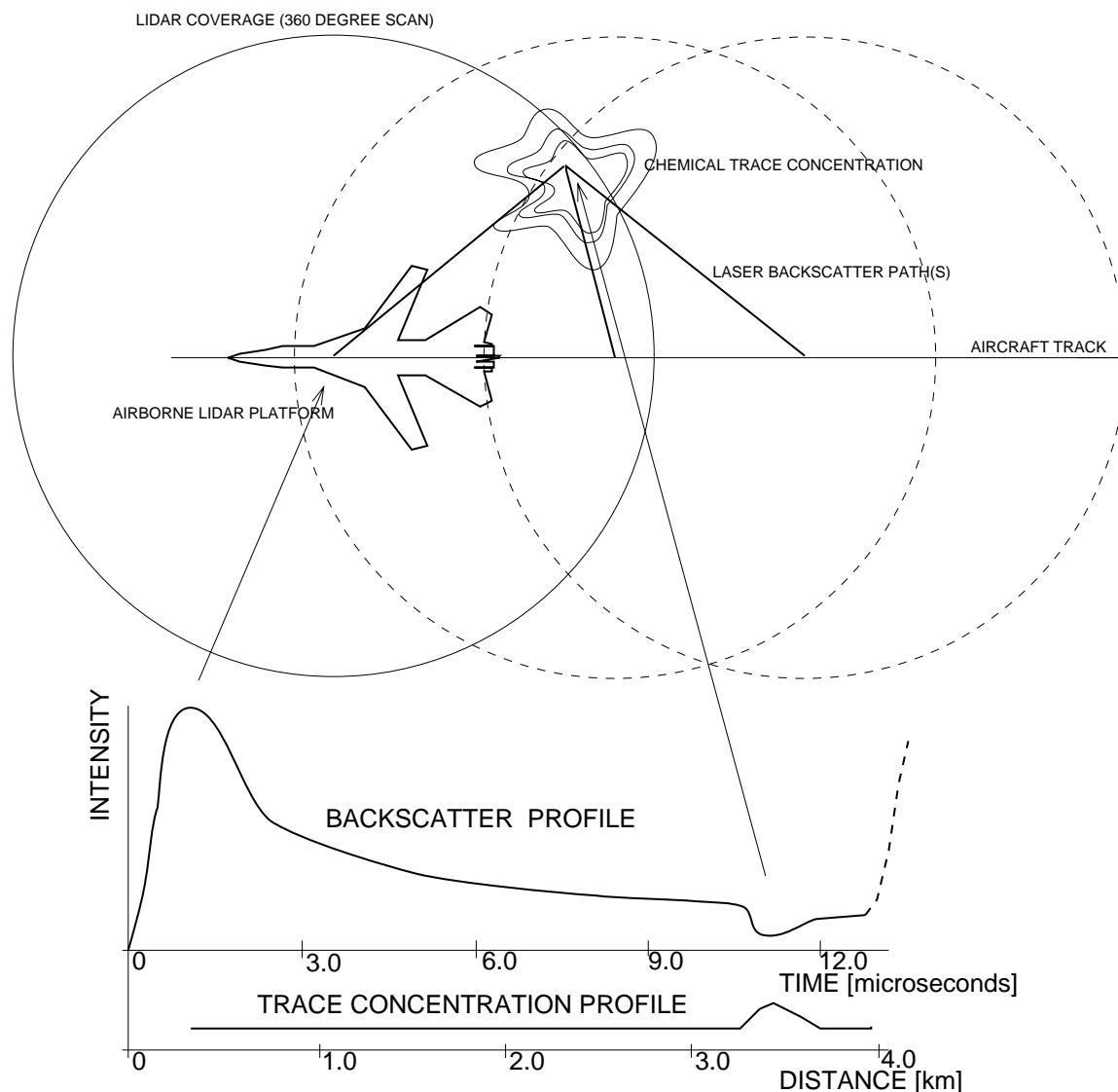

**FIG.5 SIMPLIFIED LAYOUT OF A MULTIPLE BAND LIDAR POD (RECCE SENSOR)**

sensor to share common optics.

Because the laser equipment will need to cover several bands, some of which cannot be efficiently produced by frequency multiplication of the carbon dioxide 10 micron band gas laser, such a system would carry two or more laser transmitter stages to provide the appropriate band coverage. Assuming the use of homodyne coherent detection techniques, each transmitter laser would have to be paired with a low power reference laser, acting as a master oscillator for the laser transmitter gain stages (MOPA arrangement). The reference lasers would also have to be provided with suitable tuning hardware to produce the required spectral lines for the chemical species intended to be detected, and modulators to pulse their output (eg Q-switching devices). The most complex area of the design would be the receiver and detector module, which would have to provide the capability to switch between the respective bands, and mix the received optical backscatter signal with its corresponding reference source.

In effect, this system packages two or more Lidars together, with shared common optics and detector/receiver chain. Signal processing and recording hardware would also be shared.



**FIG 6. CIRCULAR SCAN PATTERN AIRBORNE LIDAR ARRANGEMENT - RECCE**

Alternative schemes for scanning the laser do exist. Where the receive channel sensitivity is suitable for recording a concentration profile against distance (ie sampling the backscatter as the beam pulse propagates outward, rather than only the ground return), a horizontal circular scan may be used [Fig.6, Fig.7]. In



this arrangement, any point in the area covered by the system will be scanned through many times as the aircraft passes abeam this point. This combination of scan and data sampling would then allow for the averaging of the large number of readings which will cover each point along the track, thus enhancing the signal to noise ratio of the system. This translates into a gain in net system sensitivity and thus useful detection range. The evident drawback of this scheme is that the aircraft would have to carry out its run at a low altitude, thus exposing it to hostile fire. This processing scheme would also be suitable for the arrangement depicted in [Fig.2.2], providing that the receiver and data sampling scheme are appropriate, and represents an alternative to tomographic methods for the extraction of an accurate map in a sidelooking system. Selective sector scan [Fig.2.2] is easily implemented by manipulating the time during which the Lidar is active. Allowances will need to be made for Doppler shifts due platform motion, and the optics will need to be stabilised in space to avoid beam jitter due platform rolling, pitching and yawing motion. Should Lidar detection range be suitable, this arrangement allows the aircraft to fly abeam the area of interest, rather than over it.

The aerodynamic fairing will produce a blind sector under the nose of the aircraft, but this is of no consequence as the Lidar's aft sector coverage will plug the resulting hole.

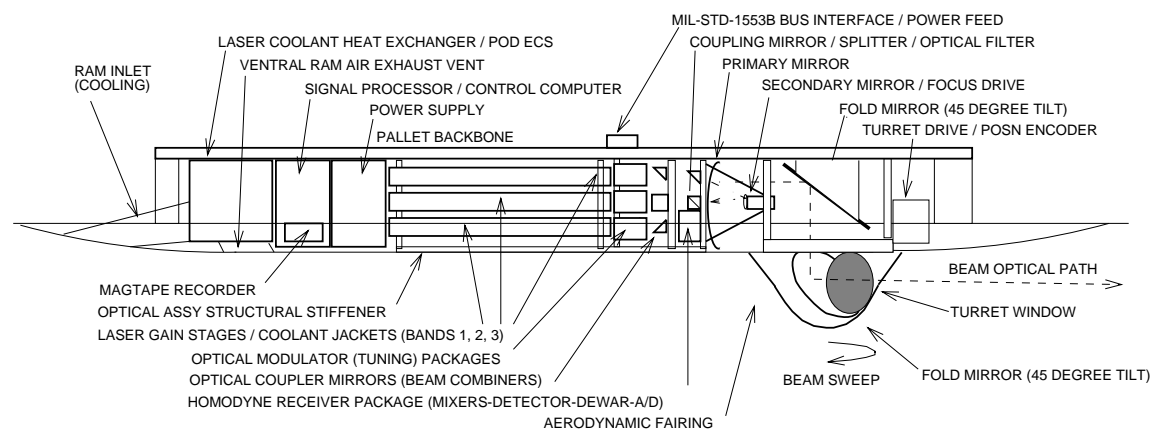

**FIG.7.1 SIMPLIFIED LAYOUT OF A MULTIPLE BAND LIDAR ATTACK/RECCE SENSOR PALLET**

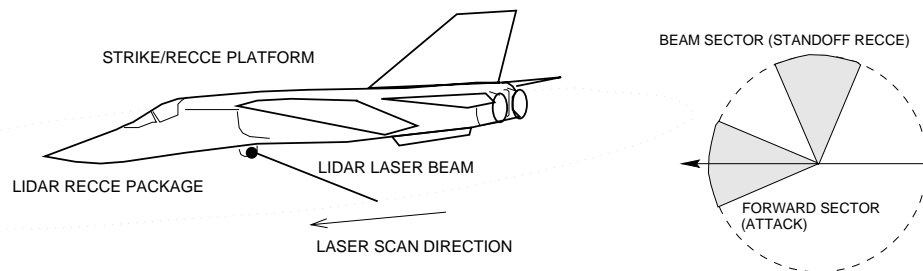

**FIG 7.2. CIRCULAR (PPI) SCAN PATTERN AIRBORNE LIDAR ARRANGEMENT**

A variation on this scheme which can provide a 3 dimensional map, at the expense of detection range and averaging of readings, is a conical scan. In this arrangement, the system in [Fig.7] is altered by depressing the beam below the plane of the aircraft's flight. The same net coverage is achieved, but each beam slices through a range of altitudes, thereby producing a map of concentration vs altitude and geographic position. This scheme is less constraining in terms of usable altitudes for the measurement run over the target area, but is weaker in detection range performance.

Another alternative approach to laser scanning is to use a raster scanning technique. This method, combined with suitable postprocessing, allows for imaging of the area of interest. The drawback of this method is that it requires a fast two-dimensional scan, which in turn demands a very high laser pulse frequency as well as the ability to rapidly retune the laser. If such a Lidar can be built economically, it would provide the optimal style of display for a BDA application.

Whether an airborne BDA Lidar should be built to provide real time analysis of target damage is an interesting question, in that should this be sought, other issues arise such as the presentation of information to the crew of the aircraft. Given the use of Lidar DIAL techniques whereby the precise tuning of the laser provides implicit calibration, a BDA device could directly output concentration numbers for each detected species. In practice the aircraft's mission computer could interrogate the Lidar once the pass is completed, and display the data in appropriate form to the crew.

With reconnaissance sensors the situation is somewhat different, in that a large amount of measurements is done over a large area, and these will need to be geographically mapped against the imagery from the thermal or optical cameras. Certainly the biggest constraint to doing very fast analyses is the computing power of the instrument. With the current generation of microprocessors and signal processors it may be a reasonable technical objective.

## 10. Conclusions

This paper has proposed the use of optical Laser Remote Sensing methods in a strike air operations environment. Basic principles, technical means and the limitations of the method are reviewed.

Suitably implemented, Laser Remote Sensing methods could be profitably applied to reconnaissance and Bomb Damage Assessment. The use of this technology in conjunction with conventional sensors provides a means of determining chemical traces in the area of interest, which for many target types can provide the necessary information to confirm target type or damage level. This can then be used to resolve uncertainties in the output from conventional sensors and available intelligence, thereby increasing the level of confidence in targeting and damage assessment.

In the Australian context, where economy of force is a critical factor, Laser Remote Sensing offers the potential for significantly more accurate strategic and tactical reconnaissance and Bomb Damage Assessment. This in turn will provide for substantially better utilisation of air assets, thereby creating a force multiplication effect within the ADF's offensive air capability. The potential payoff should not be underestimated.

## 11. Acknowledgements

Special thanks to Dr Lew Whitbourn of CSIRO DEM for his most helpful advice on the draft of this paper, and to Dr Roy Howard of ATRI for his comment on coherent detection methods. Thanks also to DSTO ESRL for their insightful review of the draft. Any omissions are the author's responsibility.

## 12. References

- EIS74 - Eisberg R.M., Resnick R., Quantum Physics, Wiley, 1974
- EVERS94 - Evers S., Aircraft System to Detect Chemicals from 100 km, AW&ST November 14, 1994
- MEASURES84 - Measures, R.M, Laser Remote Sensing, Fundamentals and Applications, Wiley Interscience, New York, 1984
- RAMO65 - Ramo Simon, et al, Fields and Waves in Communications Electronics, Wiley, 1965
- SKOOG80 - Skoog D.A., West D.M., Principles of Instrumental Analysis, 2nd Edition, Saunders College, Philadelphia, 1980
- WHITBOURN90 - Whitbourn L.B. et al, An Airborne Multiline Carbon Dioxide Laser System for Remote Sensing of Minerals, Journal of Modern Optics, 1990, Vol.37, No.11, 1865-1872
- TREAGER79 - Treager I.E., Aircraft Gas Turbine Engine Technology, 2nd Edition, McGraw-Hill, 1979

WILLIAMS80 - Williams D.H et al, Spectroscopic Methods In Organic Chemistry, 3rd Edition, McGraw-Hill (UK) Ltd, 1980